

DISIO AIRFLOW MODULE CALIBRATION NOTE:

THE DISIO AIRFLOW MODULE MUST BE CALIBRATED TO ZERO PROPERLY. TO DO THIS, CONNECT POWER AND SIGNAL WIRES AS SHOWN, AND LEAVE TUBES TO THE CROSSFLOW SENSOR DISCONNECTED. NEXT, WITH A WINDOWS COMPUTER CONNECTED TO THE DISIO DISPLAY THERMOSTAT WITH A USB-C CABLE, OPEN THE FREE DISIO SETUP SOFTWARE, GO TO THE CONFIGURATION TAB, FIND 'CALIBRATING SENSOR' AND SELECT 'INPUT2' FROM THE DROPDOWN MENU AND THEN CLICK WRITE. IF SUCCESSFUL, 'INPUT 2' WILL APPEAR IN THE NEXT LINE DOWN UNDER 'CALIBRATED SENSORS'.

*THESE STEPS PERFORMED IN DISIO SETUP CAN ALSO BE PERFORMED OVER BACNET

NOTE: XFORMER SECONDARY MUST BE GROUNDED

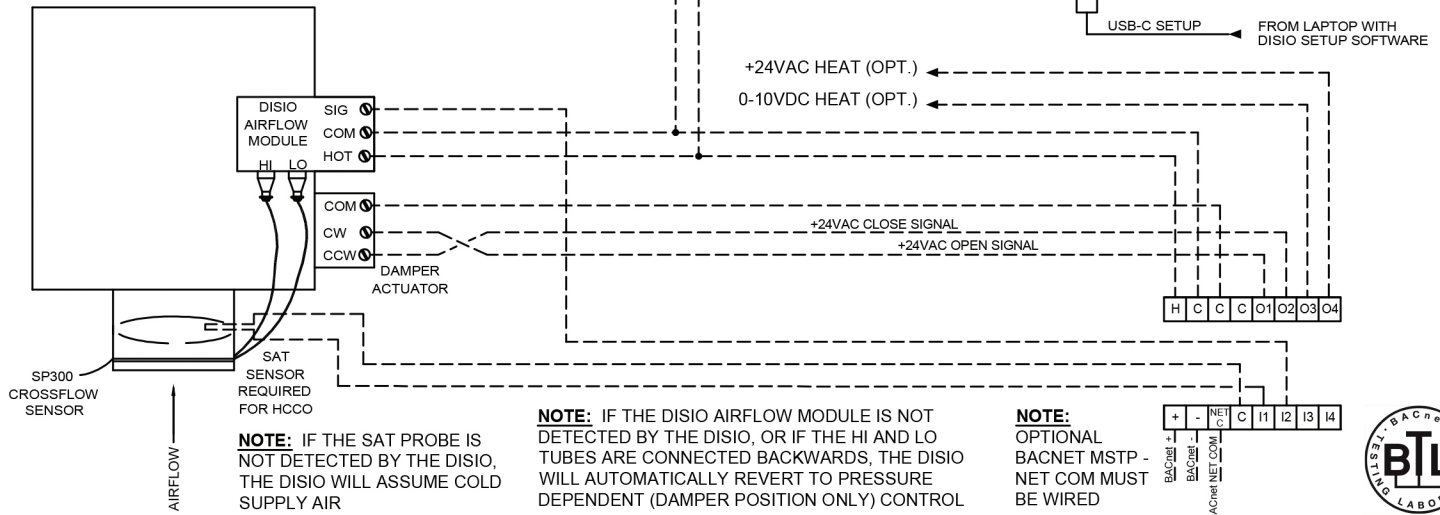

NOTE: IF THE SAT PROBE IS NOT DETECTED BY THE DISIO, THE DISIO WILL ASSUME COLD SUPPLY AIR

NOTE: IF THE DISIO AIRFLOW MODULE IS NOT DETECTED BY THE DISIO, OR IF THE HI AND LO TUBES ARE CONNECTED BACKWARDS, THE DISIO WILL AUTOMATICALLY REVERT TO PRESSURE DEPENDENT (DAMPER POSITION ONLY) CONTROL

NOTE: OPTIONAL BACNET MSTP - NET COM MUST BE WIRED



Calibration note: Suitable min and max heating flows must be selected in order to maintain flow through energized electric coils of at least 200 fpm and at least 70 cfm/kW throughout the entire operating range.

LEGEND

- FACTORY ELECTRICAL WIRING
- - - - - FIELD ELECTRICAL WIRING

CONTROL GRAPH

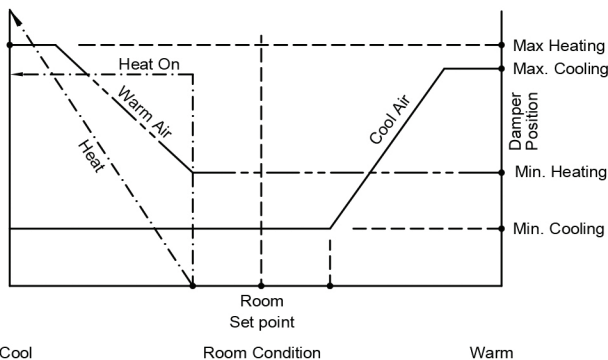

Sequence of Operation -- Heat/Cool Changeover OR Cooling With Analog Modulating Reheat - Pressure Independent

On power up the damper will calibrate closed for 2 minutes.

Cool supply air: On an increase in space temperature the controller will increase the flow of cool air. On an increase of space temperature greater than the cooling proportional band, the airflow is maintained at its pre-selected maximum value.

On a decrease in space temperature the controller will reduce the flow of cool air. If the space temperature decreases to less than the cooling proportional band, the airflow is maintained at the pre-selected minimum value.

Warm supply air: On a decrease in space temperature the controller will increase the flow of warm air. On a decrease of space temperature greater than the heating proportional band, the airflow is maintained at its pre-selected maximum setting.

On an increase in space temperature the controller will reduce the flow of warm air. If the space temperature increases above the heating proportional band, the airflow is maintained at the pre-selected minimum setting.

Reheat Operation: On a decrease in space temperature, the controller will turn on a 24VAC binary output and modulate a 0-10VDC output to increase heat proportionally to the room demand.

Visit disio.io/setup for free DISIO Setup Software compatible with Windows.

PROJECT:

ENGINEER:

CUSTOMER:

SUBMITTAL DATE:

SPEC. SYMBOL:

PRICE[®]

BC SF

**PRESSURE INDEPENDENT
TERMINAL - DISIO DISPLAY**

PRESSURE INDEPENDENT DAMPER
CONTROL WITH HCCO
AND OPTIONAL REHEAT

276206

2024/04/02